

Medium Theatre Lighting Layout GUIDE

125 CHANNELS

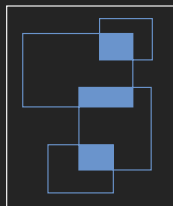

A large part of effecting sparkling creative vision is having the right tools to project what the mind sees. This brochure is equipped with all the information necessary to implement your next stage project. It includes a complete lighting design package, light plot and equipment list, the latest in Altman equipment and provides an example of how the different fixtures are used. It is meant to serve as a starting point for budgeting and planning and to bring *your imagination to light*. For more information, contact your local Altman sales representative.

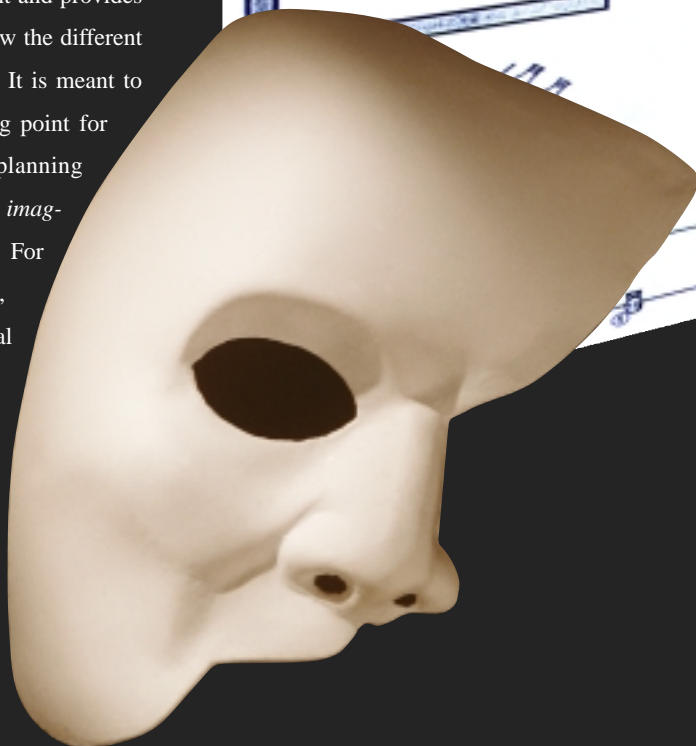
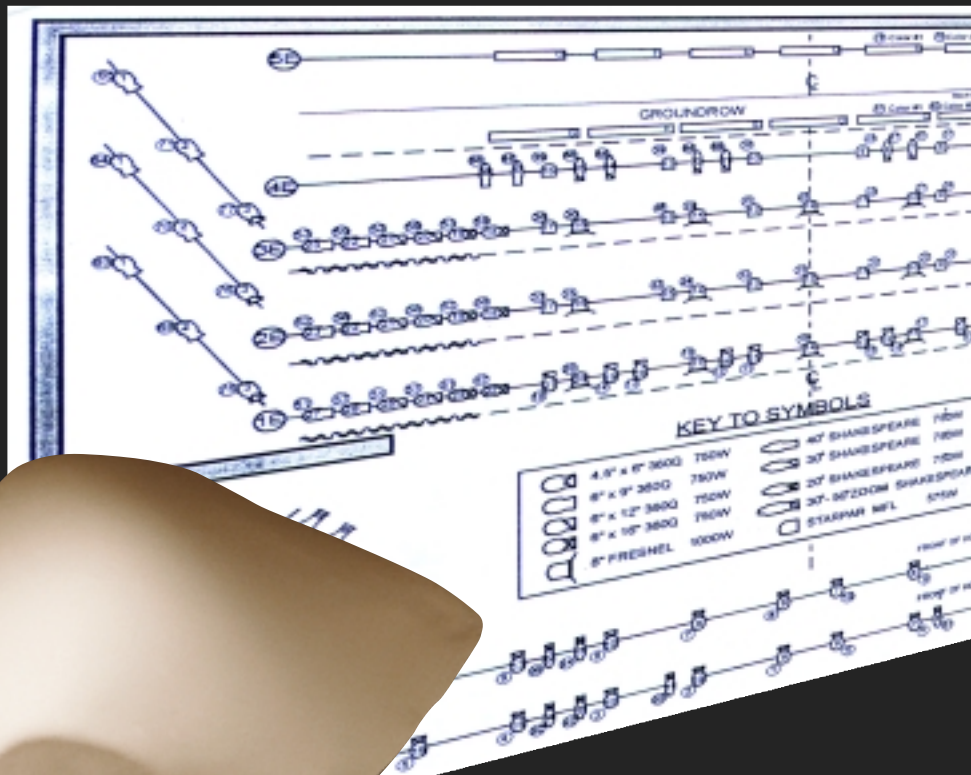

ALTMAN

BRINGING IMAGINATION TO LIGHT



Medium Theatre Layout

The Medium theatre package is intended for theatres with a stage approximately 40' wide and 30' deep. It uses 125 control channels, a common size in computerized control boards. It is designed to use 96 – 2.4Kw dimmers. Again, 96 is an industry standard size. In addition, there are 6 – 6.0Kw dimmers. There are extra circuits at each position.

The design is based on the principal of dividing the stage into “areas.” There are 15 of these areas each approx. 8'-0” in diameter. Each area has a variety of lamps assigned to light it from different angles, and colors. This system provides an efficient and flexible way to control what areas of the stage are bright and more importantly, which areas are dark. It is very useful for all types of performance, plays, musicals, operas, choirs, or dance. As the productions become more complex, they will need to have specific lighting designed to accommodate the production. Contact a lighting designer or consultant for an accurate evaluation. This package provides enough equipment to be re-arranged in a variety of different ways.

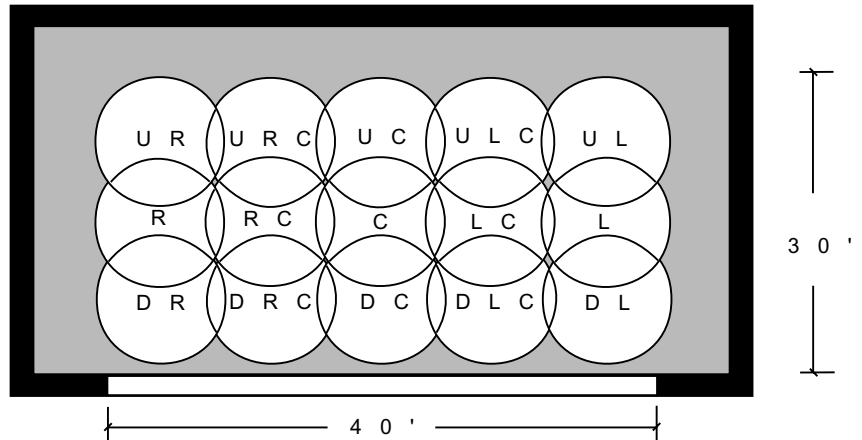

- 1 *Shakespeare*
- 2 *Comet Follow Spot*
- 3 *Star Par*
- 4 *360 Q*
- 5 *Focusing Cyc*
- 6 *IKAF Fresnel*

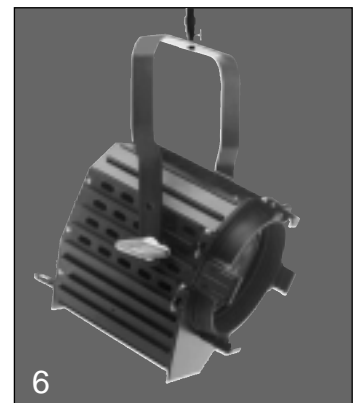
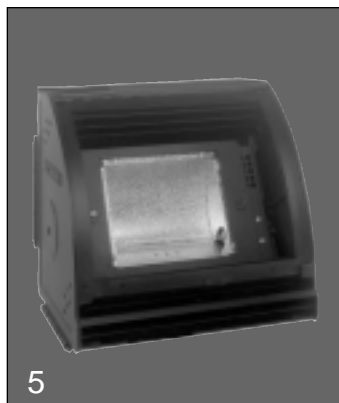
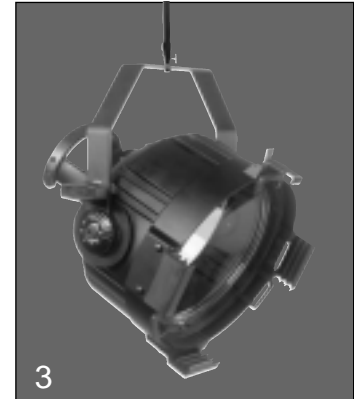

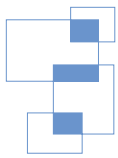

Medium Theatre Layout

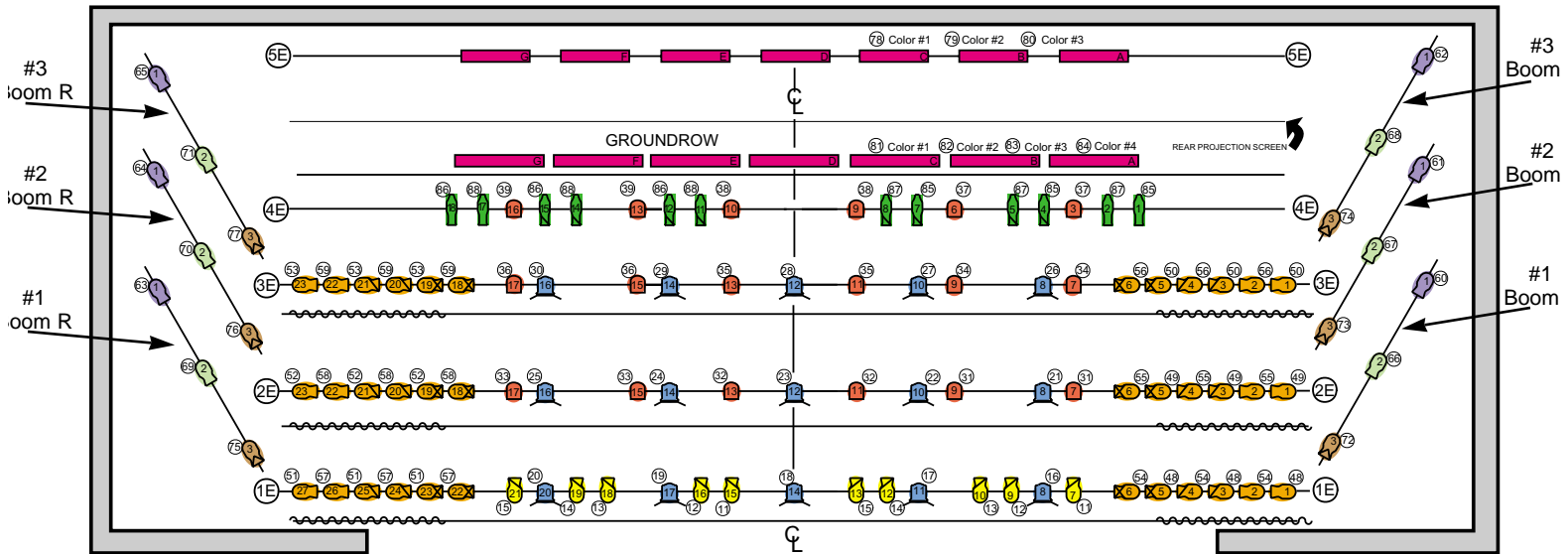

KEY TO SYMBOLS

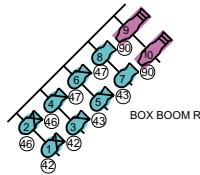

	4.5" x 6" 360Q 575W - 750W		40° SHAKESPEARE 575W - 750W
	6" x 9" 360Q 575W - 750W		30° SHAKESPEARE 575W - 750W
	6" x 12" 360Q 575W - 750W		20° SHAKESPEARE 575W - 750W
	6" x 16" 360Q 575W - 750W		30° - 50 ZOOM SHAKESPEARE 750W
	8" FRESNEL 1000W		STARPAR MFL 575W

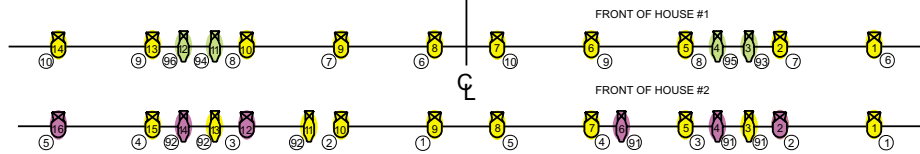
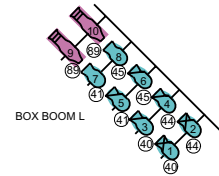

AREA LIGHT: THESE FIXTURES PROVIDE BASIC FRONTAL ILLUMINATION. THE STANDARD ACTING AREA PRODUCES SHADOWS ON THE FACE THAT MOST NEARLY APPROXIMATE THOSE FOUND IN OUTDOOR LIGHTING ON A SUNNY DAY. IF ONE OF THE TWO FIXTURES IS EQUIPPED WITH A WARM TINT, FOR EXAMPLE, STRAW, AND THE OTHER WITH A COOL TINT, FOR EXAMPLE, DAYLIGHT BLUE THE EFFECT WILL BE EVEN MORE REALISTIC. SUCH AREAS ARE OFTEN RUN FROM SINGLE DIMMERS WITH CONSIDERABLE SUCCESS. (WILLARD BELLMAN - LIGHTING THE STAGE, ART & PRACTICE 1967)

FRONT DIAGONAL - IS USED TO PROVIDE A WASH OF COLOR ACROSS THE STAGE. IT IS POSITIONED AT AN ANGLE SO THAT THE LIGHT DOES NOT CAST A SHADOW ON THE CYCLORAMA OR BACKDROP. VERY USEFUL FOR TONING AN ENTIRE SCENE IN ONE OR MORE COLORS FOR EXAMPLE AN EFFECTIVE SUNRISE OR SUNSET CAN BE CREATED BY USING WARM TONES IN THE LEFT WASH, AND COOL TONES IN THE RIGHT WASH. ALSO AN EXCELLENT ANGLE FOR ADDING TEXTURE TO A SCENE THROUGH THE USE OF TEMPLATES.

BACK LIGHT - IS USED TO CREATE DEPTH IN THE STAGE PICTURE. IT PROVIDES A STRONG HIGHLIGHT ALONG THE SHOULDERS AND BACK OF THE HEAD OF THE PERFORMER. IT IS THE MOST EFFECTIVE WAY TO MAKE THE PERFORMER "POP" IN FRONT OF THE SCENERY.

BACK DIAGONAL - IS USED TO CREATE A WASH OF LIGHT FROM UPSTAGE TO DOWNSTAGE WITH ALL OF THE SHADOWS FALLING IN THE SAME DIRECTION. USEFUL FOR SIMULATING THE SUN OR MOON LIGHT

DOWN LIGHT - USED TO PROVIDE ISOLATION OF SELECTED PARTS OF A SCENE. IS VERY HELPFUL IN PROVIDING DEPTH, AND ADDING COLOR TONES.

CYC LIGHT - USED TO PROVIDE A WASH OF COLOR ON THE CYCLORAMA OR BACKDROP. A VARIETY OF LOOKS CAN BE CREATED USING THREE COLORS ON TOP AND FOUR COLORS ON THE BOTTOM

CYC LIGHT - USED TO PROVIDE A WASH OF COLOR ON THE CYCLORAMA OR BACKDROP. A VARIETY OF LOOKS CAN BE CREATED USING THREE COLORS ON TOP AND FOUR COLORS ON THE BOTTOM.

PIPE END - THIS LIGHT IS FOR SCULPTING THE BODY AND REVEALING THREE DIMENSIONAL FORMS. IT IS VERY USEFUL FOR MAKING THE PERFORMERS STAND OUT AGAINST THE BACKGROUND. THE LIGHT IS GROUPED INTO "LANES" WHICH CONSIST OF APPROXIMATELY TWO AND A HALF AREAS IN ROW LEFT TO RIGHT. FOR EXAMPLE THE DOWNSTAGE FIXTURES WOULD FOCUS THE FIRST UNIT HALFWAY BETWEEN DL AND DC. THE SECOND UNIT WOULD FOCUS HALFWAY BETWEEN DR AND DC. THEY BLEND TOGETHER TO FORM A PATH, WHICH ONLY LIGHTS PERFORMERS ON THE DOWNSTATE LINE OF AREAS. THIS IS USEFUL TO CREATE DEPTH IN THE STAGE PICTURE, BY HAVING PERFORMERS AT DIFFERENT DISTANCES UPSTAGE APPEAR AT DIFFERENT INTENSITIES.

LOW SIDE - THIS IS LIGHT THAT COMES FROM A LOW ANGLE FROM THE SIDES OF THE STAGE. IT IS EXCELLENT FOR SCULPTING THE BODY AND PROVIDING DIMENSION TO FORMS.

HEAD HIGH - THIS IS SIDE LIGHT THAT COMES FROM THE SIDES OF THE STAGE AT A HEIGHT OF 6'-0". IT IS EXCELLENT FOR SCULPTING THE BODY AND PROVIDING DIMENSION TO FORMS. ALSO AN EXCELLENT SOURCE FOR ADDING COLOR TO A SCENE.

SHINS - THIS IS LIGHT THAT COMES FROM A VERY LOW ANGLE FROM THE SIDES OF THE STAGE. IT IS OFTEN FOCUSED SO THAT THE LIGHT CAN BE SHUTTER CUT OFF THE FLOOR. THIS CREATES THE ILLUSION OF THE PERFORMERS FLOATING ABOVE THE STAGE.

TEMPLATE WASH - A GENERAL CIRCUIT FOR ADDING TEXTURE/PROJECTIONS TO A SCENE. THE DESIGNERS IMAGINATION IS THE ONLY LIMITING FACTOR.

SPECIAL - THIS IS A GENERIC TERM FOR ANY LIGHT THAT HAS A UNIQUE FOCUS SPECIFIC TO A PARTICULAR PERFORMANCE OR SCENE. IT CAN BE THOUGHT OF AS A WILDCARD.

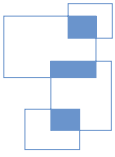

Medium Theatre Specs

FIXTURES

ALL FIXTURES ARE U.L. AND c.U.L. LISTED FOR WATTAGE SPECIFIED

6	360Q-4.5X 6.5	4.5" X 6.5" ELLIPSOIDAL AXIALLY MOUNTED QUARTZ SPOTLIGHT 575W
28	360Q-6X 9	6"X9" ELLIPSOIDAL AXIALLY MOUNTED QUARTZ SPOTLIGHT 575W
30	360Q -6X12	6" X 12" ELLIPSOIDAL AXIALLY MOUNTED QUARTZ SPOTLIGHT 575W
36	360Q -6X16	6" X 18" ELLIPSOIDAL AXIALLY MOUNTED QUARTZ SPOTLIGHT 575W
4	S6-40	40° SHAKESPEARE SERIES ELLIPSOIDAL SPOTLIGHT 575W
12	S6-30	30° SHAKESPEARE SERIES ELLIPSOIDAL SPOTLIGHT 575W
10	S6-20	20° SHAKESPEARE SERIES ELLIPSOIDAL SPOTLIGHT 575W
4	S6-3050Z	30° - 50° SHAKESPEARE SERIES ELLIPSOIDAL ZOOM SPOTLIGHT 575W
15	1KAF	6" DIE-CAST FRESNEL 1000W
18	SP-A	STAR PAR DIE-CAST SPOTLIGHT/FLOODLIGHT 575W
49	FC-1	FOCUSING CYC - GROUND AND SKY CYC LUMINAIRE 300-1500W

FOLLOWSPOTS

2	COMET	COMET FOLLOWSPOT 360/410W
---	-------	---------------------------

HARDWARE

10	509-24-2	24" DOUBLE TEE SIDE ARM
36	509-18-1	18" SINGLE TEE SIDE ARM

ACCESSORIES

100	6-SN	BLACK SNOOT FOR 360Q
26	S6-4.5-SN	BLACK SNOOT FOR SHAKESPEARE
18	8-SN	BLACK SNOOT FOR STAR PAR
6	SDii	DROP-IN IRIS FOR SHAKESPEARE
18	360PH	PATTERN HOLDER FOR 360Q AND SHAKESPEARE
18	4.5-DN	BLACK DONUT FOR SHAKESPEARE
15	6-BD-4	4 - WAY BARNDOR FOR 6" FRESNEL
18	6-DN	BLACK DONUT FOR 360Q
18	97-0150	COMPLETE LENS SET FOR STAR PAR
18	510	MALLEABLE IRON PIPE CLAMP
7	FC-3Y	W/HARDWARE KIT
7	FC-4Y	W/HARDWARE KIT

DISTRIBUTION

7	300-138GF	30'-0" RACEWAY WITH 12 CIRCUITS AND 24 PIGTAILS ON 1'-6" CENTERS (FOH #1, #2, 1st, 2nd, 3rd, 4th. & 5th. elec.)
2	300-138GF	9'-0" RACEWAY WITH 6 CIRCUITS AND 12 PIGTAILS ON 1'-6" CENTERS (Box Boom L&R)
5	4-512-L	CABLE CRADLE FOR MOVING ELECTRICS
10	FF-701-4-GPC	FLOOR POCKET WITH 4 CIRCUITS

DIMMING & CONTROL

1	125 CHANNEL CONTROL CONSOLE BY OTHERS
96	2.4Kw DIMMERS BY OTHERS
6	6.0Kw DIMMERS BY OTHERS
4	PLUG-IN STATIONS BY OTHERS

SEND FOR FREE THEATRE KIT!

All the information you need to make a professional presentation is included in Altman's free Theater Kit. Created to ensure that your theater will be properly lit, it includes all the necessary specifications and materials for your project so that it can be directly used by your designer or architect, or to help you win the funding you need.

For more information, call
914-476-7987
or visit our Web site at <http://www.altmanltg.com>.



ALTMAN
BRINGING IMAGINATION TO LIGHT

Altman Stage Lighting, Company • 57 Alexander Street, Yonkers, NY 10701
PH: 914. 476.7987 FAX: 914. 963.7304.